



# **Avaya Smart City Solutions**



# Executive Summary

**City administrators** need a smart city strategy for more sustainable development, wiser resource management, enhanced quality of life, citizen safety, and increased economic opportunities.

At the heart of this strategy is **people and communication.**

# Intelligently Connecting Citizens and Employees of the City Administration Through a Smart City Ecosystem

## The dual core of Avaya's smart city solutions:

1. Real-time situational awareness for faster reactions to urban events
2. Omni-channel citizen engagement anytime, anywhere on any device

## Business outcomes:

- **Faster** and more efficient **problem resolution**
- More relevant, meaningful **engagement with preferred forms of communication** for citizens to interact with smart city services
- **Real value** derived from data-driven insights
- **Seamless and contextual connections** between machines, humans and LOB applications

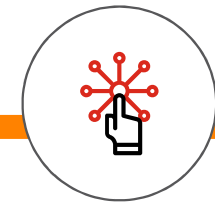

Ensuring the **right information** is in the **right place** at the **right time**, maximizing business outcomes.



## Key Points

- Service and workflow **automation**
- **Actionable IoT** and ecosystem data
- **Contextual processing** of Ecosystem data
- **AI** and analytics
- **Proactive ecosystem monitoring** and citizen engagement
- **Real-time omni-channel** mass notifications
- **Agile workflows** for more efficient business outcomes



**Uniquely automating processes and seamlessly connecting citizens and employees city-wide**

# IoT-enabled Ecosystem

## Trends

- Internet of Things
- Machine to Machine

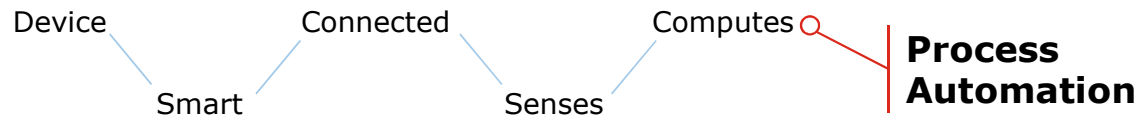
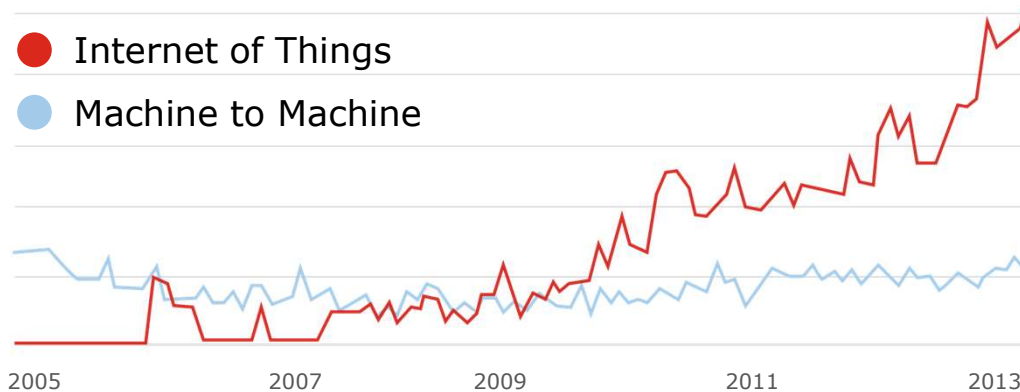

Interconnecting devices, systems and processes

IoT as an enabler of the smart city infrastructure, **gathering** and **analyzing** key data

**Real value** derived from data-driven insights

Opens the door for new, compelling use cases across key city areas (i.e. healthcare, municipal services, public safety)

# “If This Then That” 2.0 For Organizations

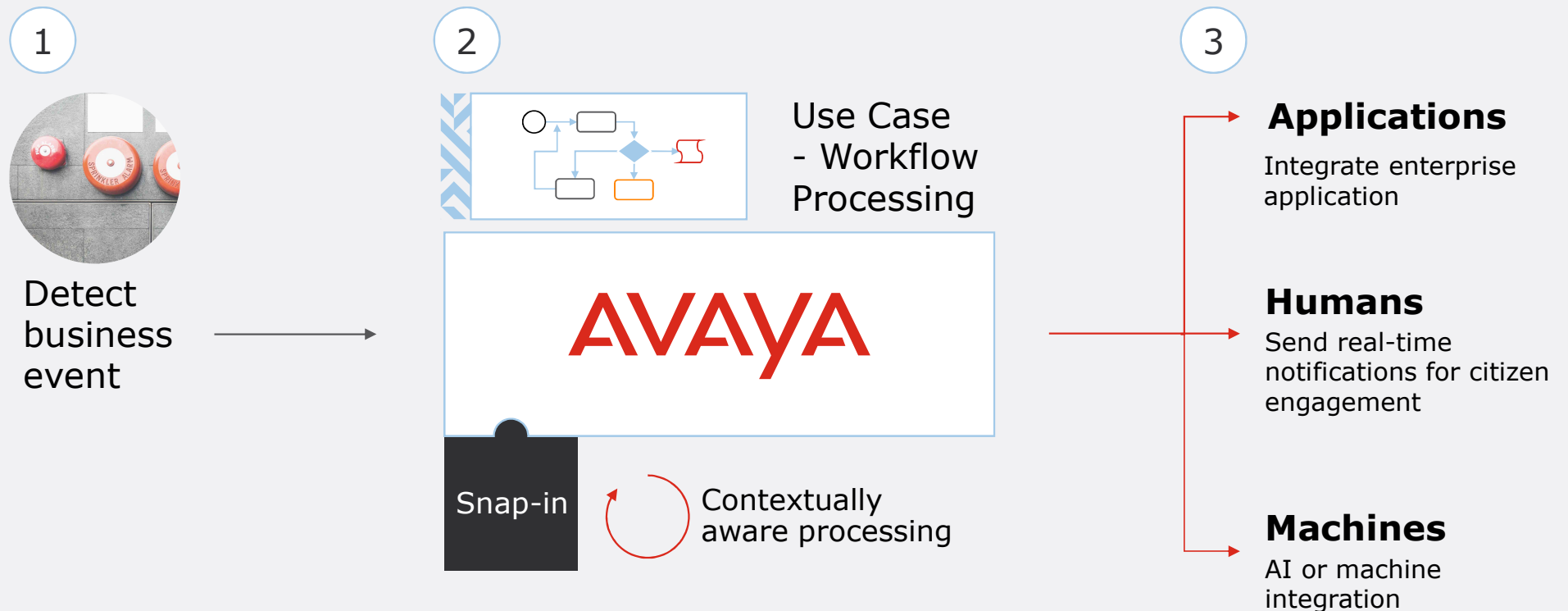

# Service Automation & Orchestration

Open and Agile by Default

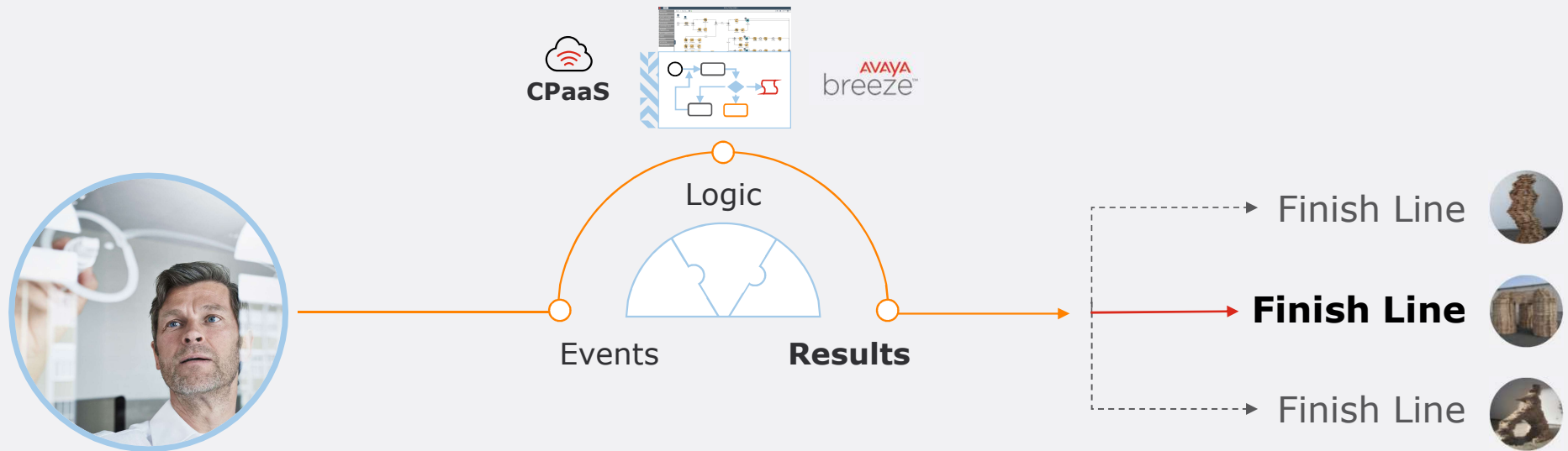

**Discovery Workshop**   **Definition Use Case**   **Value Proposition**

**Implementation**

**Design for Change**

Quick and flexible implementation

Agile

# Create and Customize Workflows

## Avaya Engagement Designer

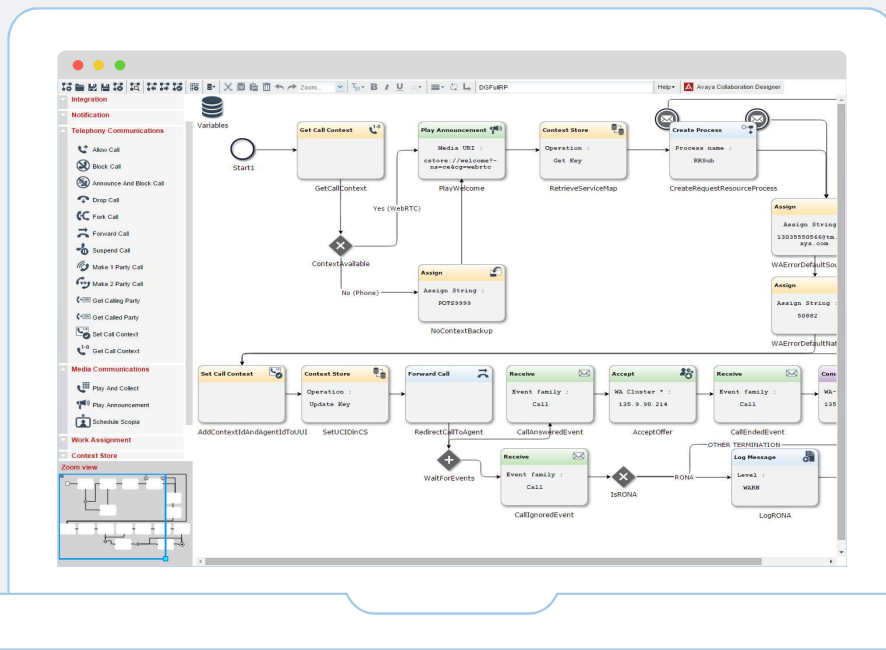

### Browser-based visual designer for workflow design and automation

- Quickly create applications with minimal programming experience
- Seamless integration into IoT, AI and LOB Applications
- Create your own task types and dynamically incorporate them into the palette
- Visual, drag-and-drop model for tailoring and customizing workflows

Simplify how you create and control your business processes





# Avaya & IoT

## Smart Communications for Smart Engagement

Delivers intelligent outcomes

**Contextually-aware**  
Processing

Actionable  
**IoT Data**

Agile **Workflow**  
**Automation**

**Open Ecosystem** for  
Smart Communication

**Seamless and contextual** connections between machines, humans and LOB applications

# What Defines a Smart City

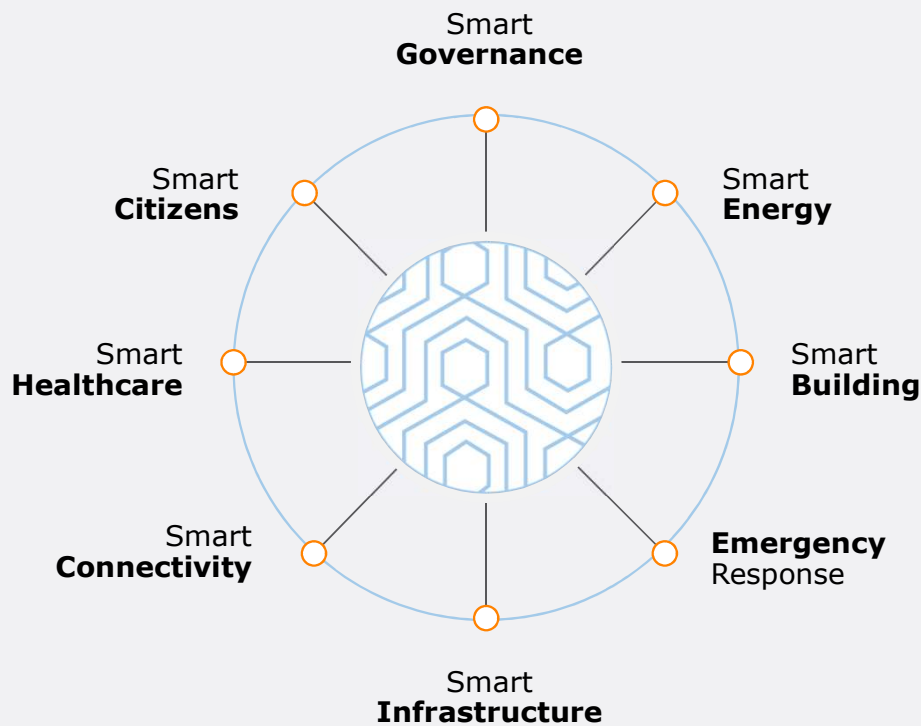

## Smart Solutions

### E-Governance and Citizen Services

- ① Public Information, Grievance Redressal
- ② Electronic Service Delivery
- ③ **Citizen Engagement**
- ④ Citizens – City’s Eyes and Ears
- ⑤ Video Crime Monitoring

### Energy Management

- ⑬ Smart Meters & Management
- ⑭ Renewable Sources of Energy
- ⑮ Energy Efficient & Green Buildings

### Waste Management

- ⑥ Waste to Energy & fuel
- ⑦ Waste to Compost
- ⑧ Waste Water to be Treated
- ⑨ Recycling and Reduction of C&D Waste

### Urban Mobility

- ⑯ Smart Parking
- ⑰ Intelligent Traffic Management
- ⑱ Integrated Multi-modal Transport

### Water Management

- ⑩ Smart Meters & Management
- ⑪ Leakage Identification, Preventive Maint.
- ⑫ Water Quality Monitoring

### Others

- ⑲ Tele-Medicine & Tele Education
- ⑳ Incubation/Trade Facilitation Centers
- ㉑ Skill Development Centers



ILLUSTRATIVE LIST

# Intelligent Engagement

## The foundation of a Smart City

The dual core of our smart city solutions: **real-time situational awareness** for **faster reactions to events** and **omni-channel citizen engagement**.

Driving more intelligent outcomes by **uniquely automating processes** and **connecting citizens and employees** through a smart city ecosystem

Delivering value in **the way it matters most:** across the public services that citizens **consume and rely on.**



**Improved quality** of life and safety for all citizens

# The Power of an Open Ecosystem

Complete integration for continuous innovation

## Waste Management



Sensor detection and proactive engagement

Any-choice (anytime, anywhere, any-device, any-channel) citizen engagement

## Smart Parking



## Environmental Protection

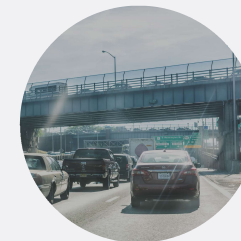

## Noise Pollution



Multi-Agency coordination and response

Break down information silos



# Smart Cities - Smart Parking

Save on time, fuel costs and emissions

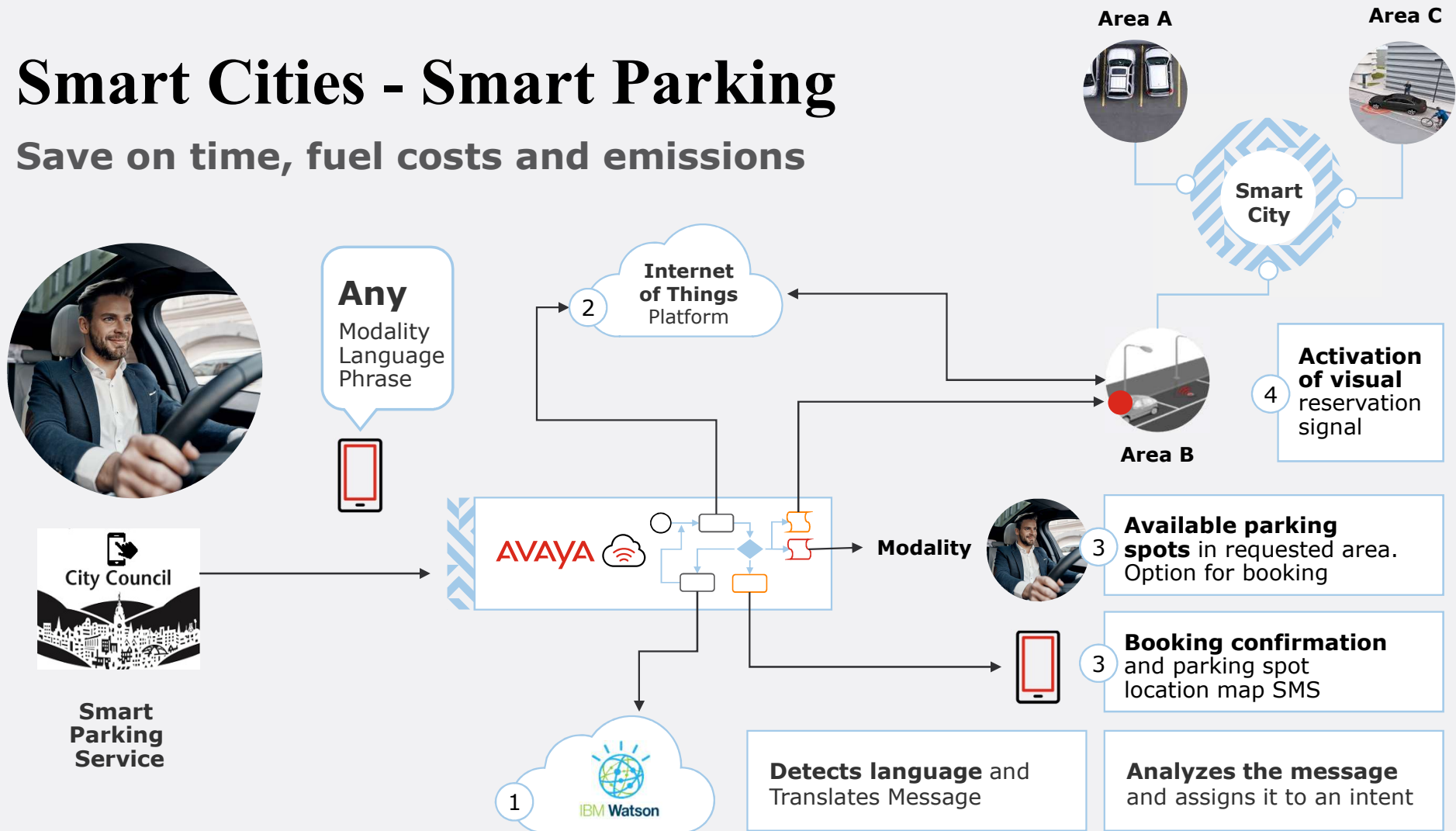



# Smart Cities - Waste Management

Situational awareness for faster response time

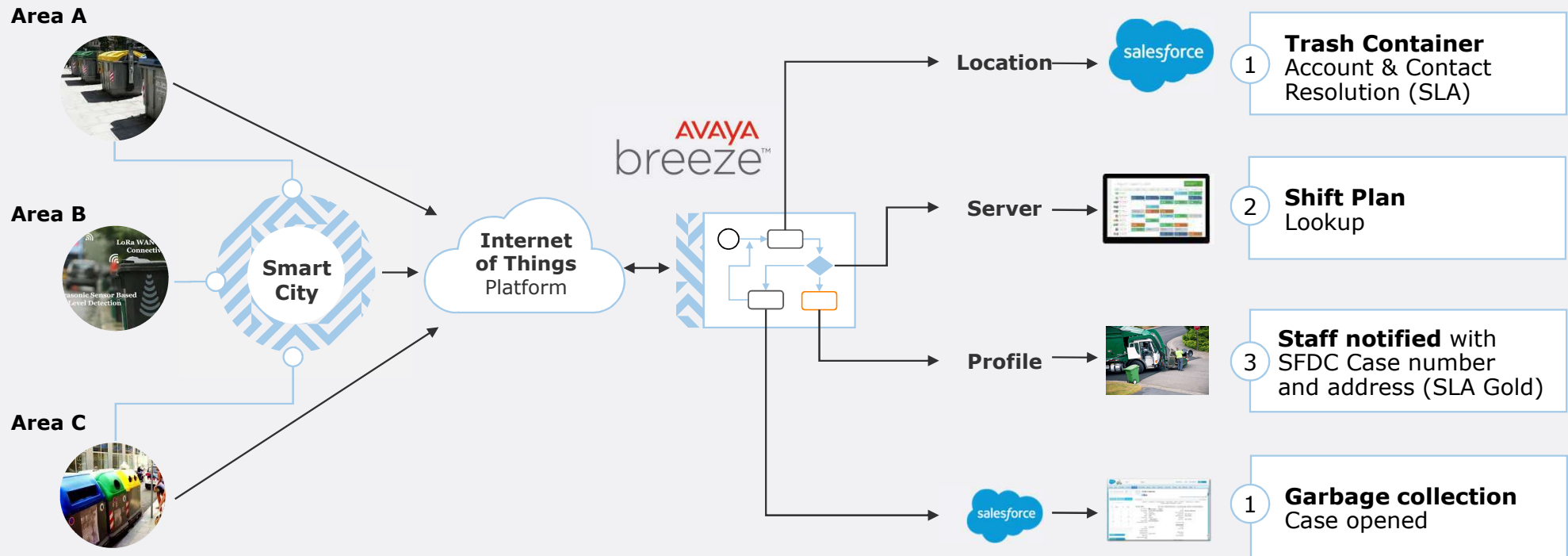

# Smart Cities - Waste Management

Situational awareness for faster response time

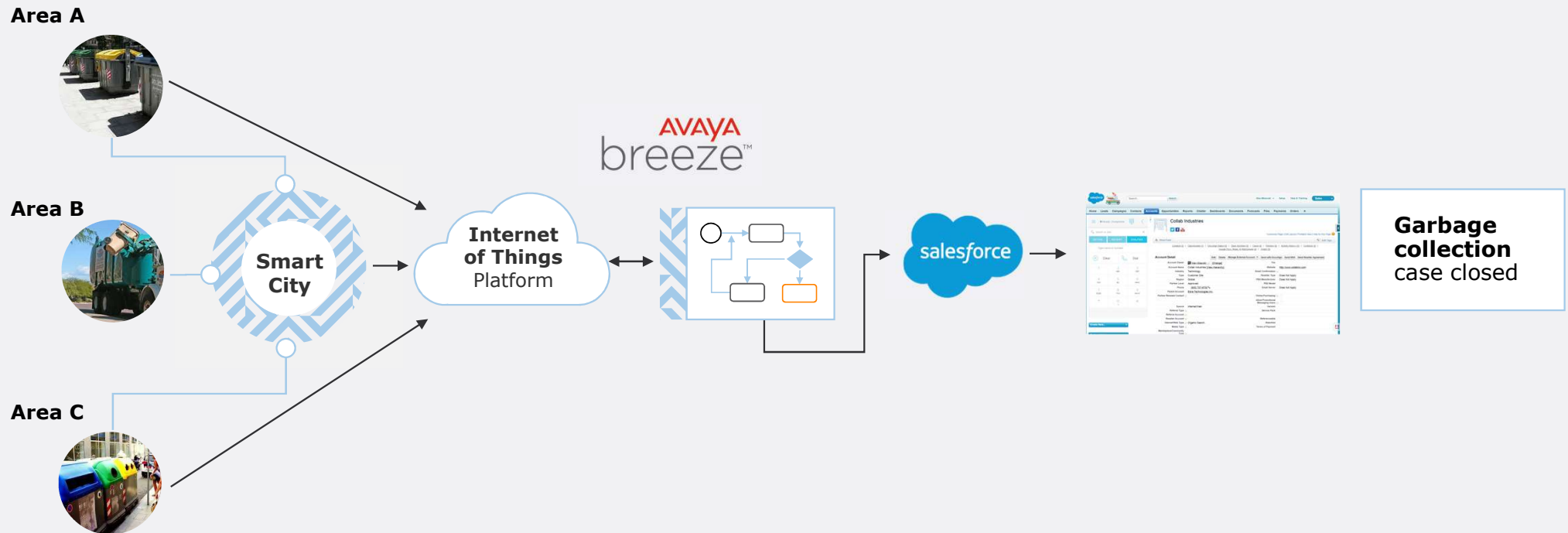



# Waste Management – Automated Workflow

Avaya Breeze

**Salesforce Account resolution**

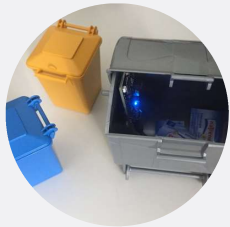

**Requesting trash level and location**

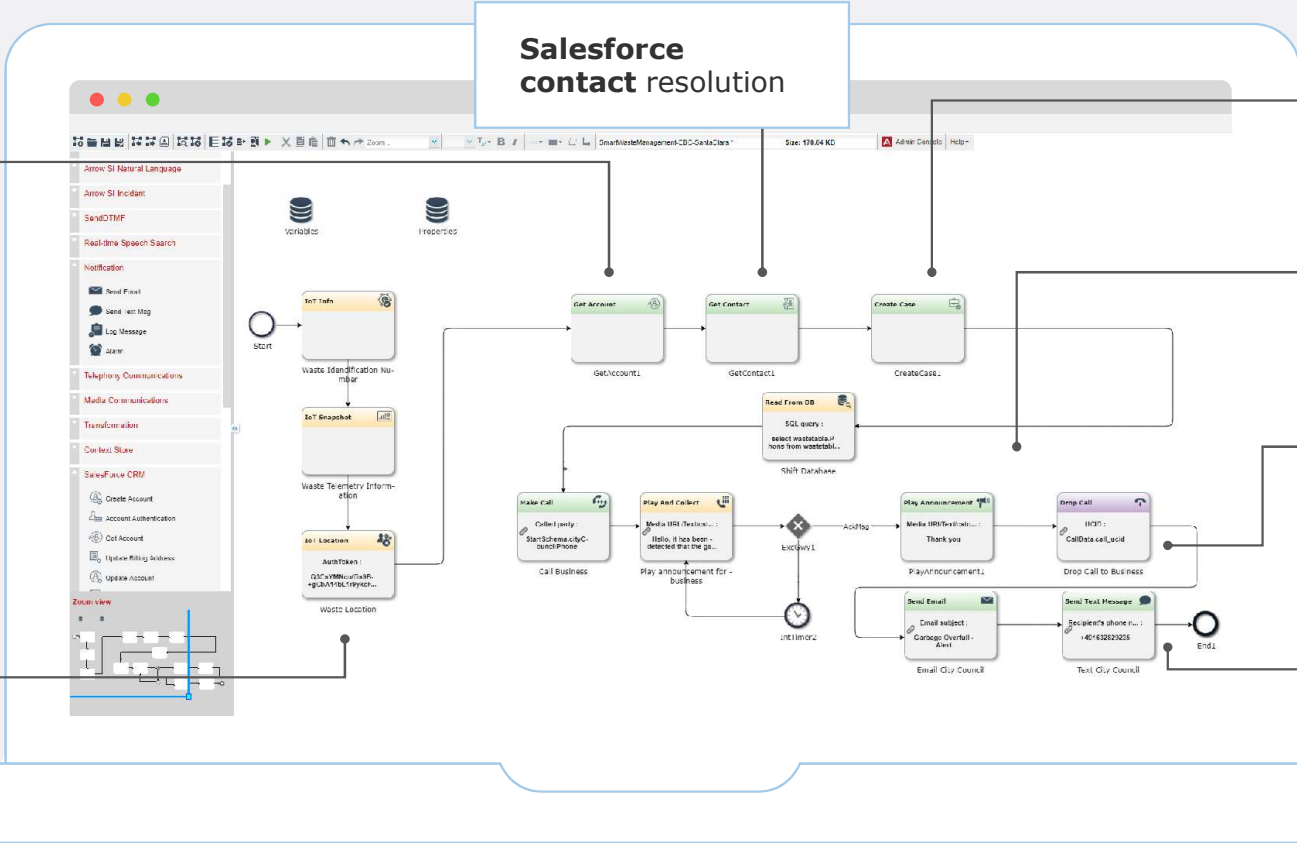

**Create Salesforce case**

**Shift plan database lookup**

**Staff notification of new case with SLA**

**Text message with case and location**

# Smart Cities - Air Pollution

## Situational Awareness for Faster Response Time

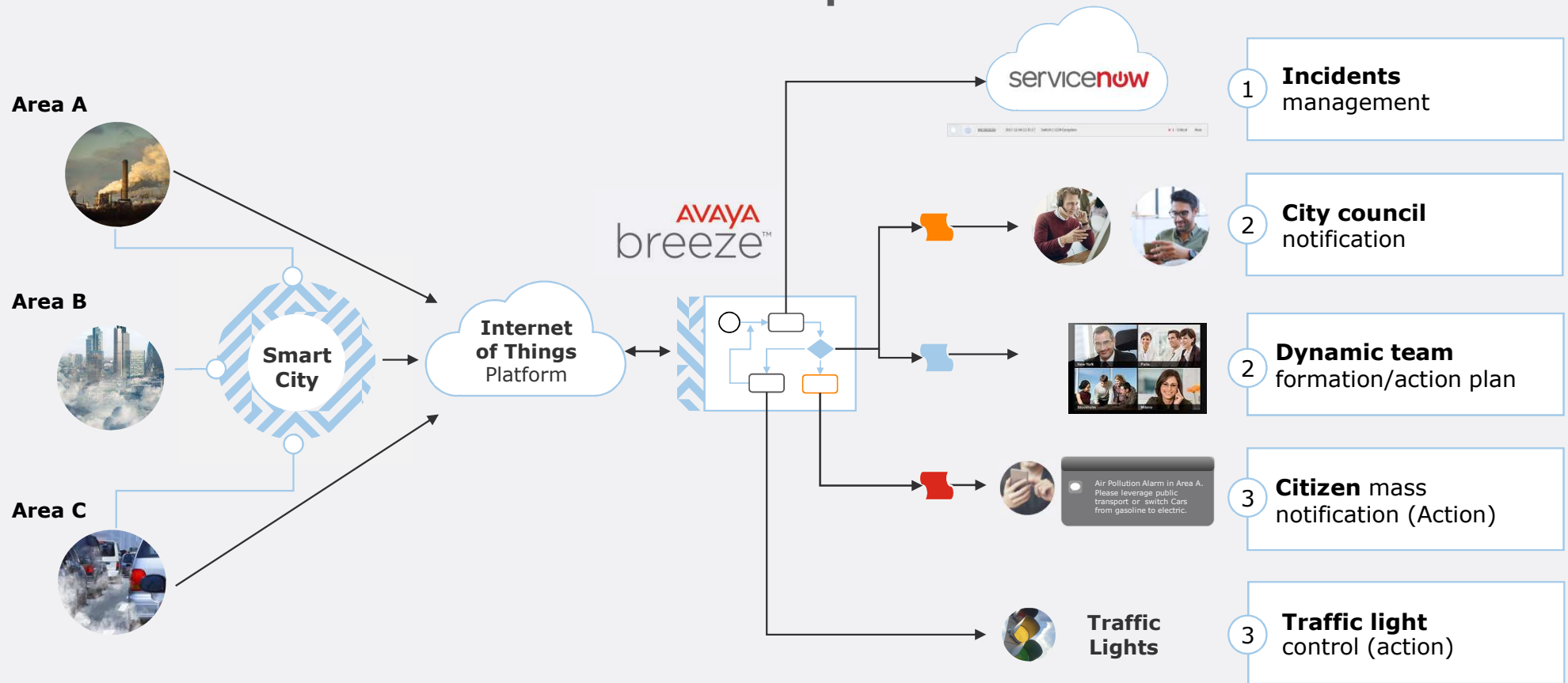

# Smart Cities - Urban Noise Monitoring

## Situational Awareness for Faster Response Time

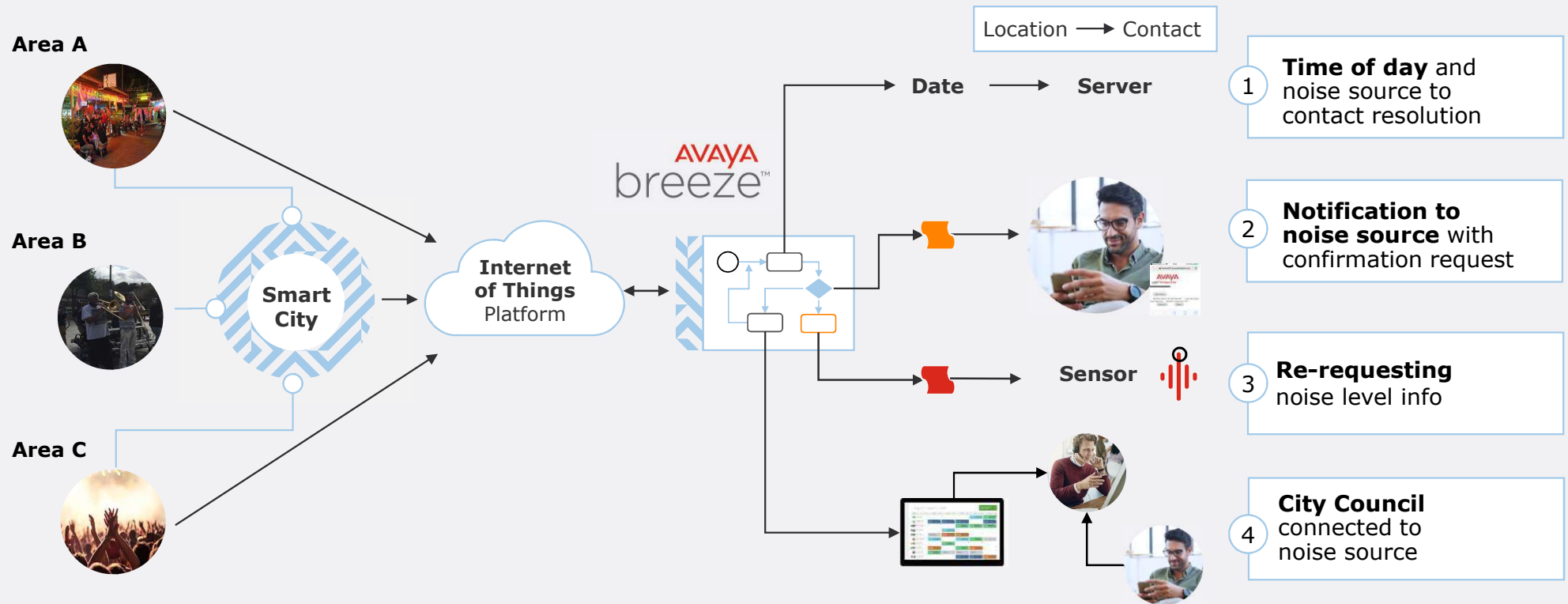

# Smart Cities - On-demand Cleaning Services

## Situational Awareness for Optimized Efficiency

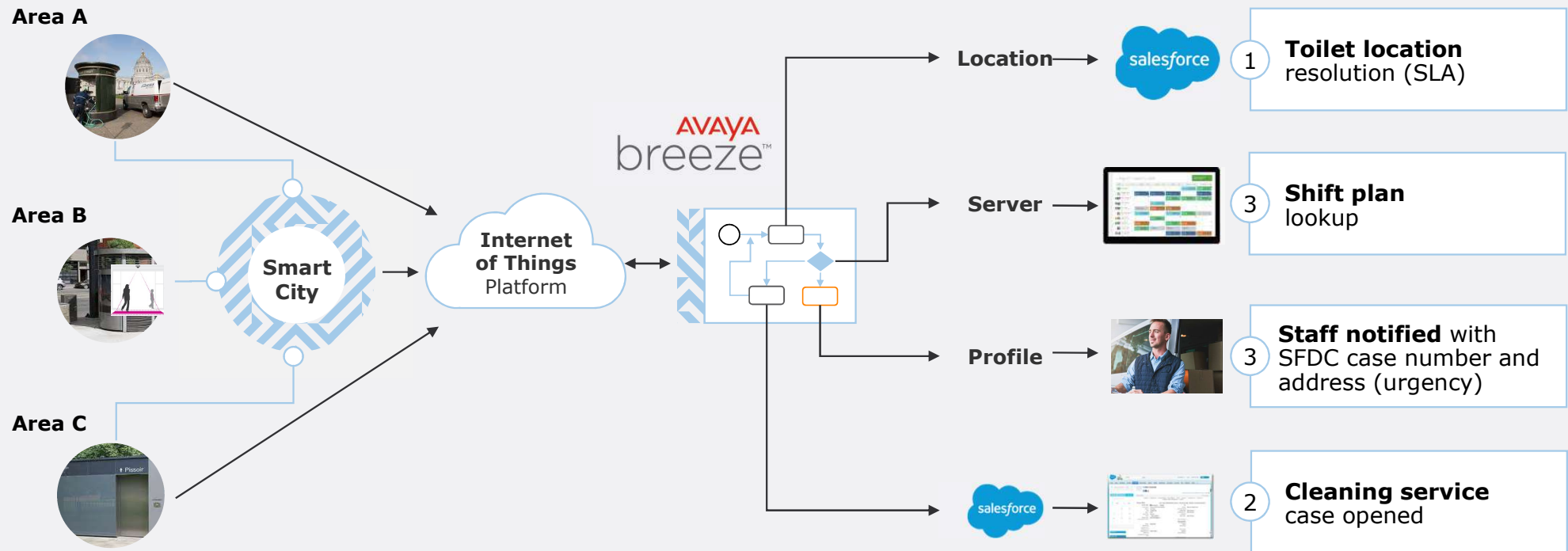

# Smart Cities - Smart Metering

Creates a Win-win with IoT Data Insights

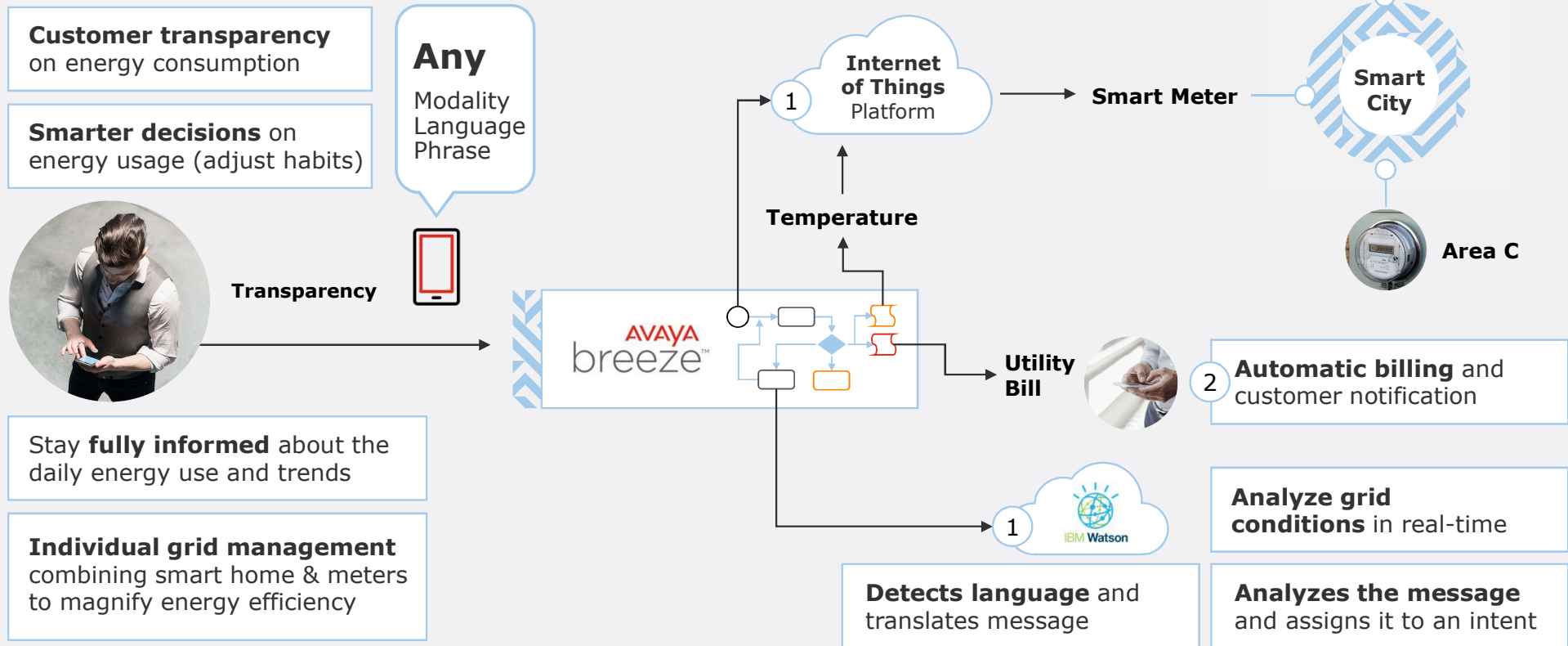

# Blending Digital Into The Physical Experience

## Seamless integration of Stand-alone Technologies

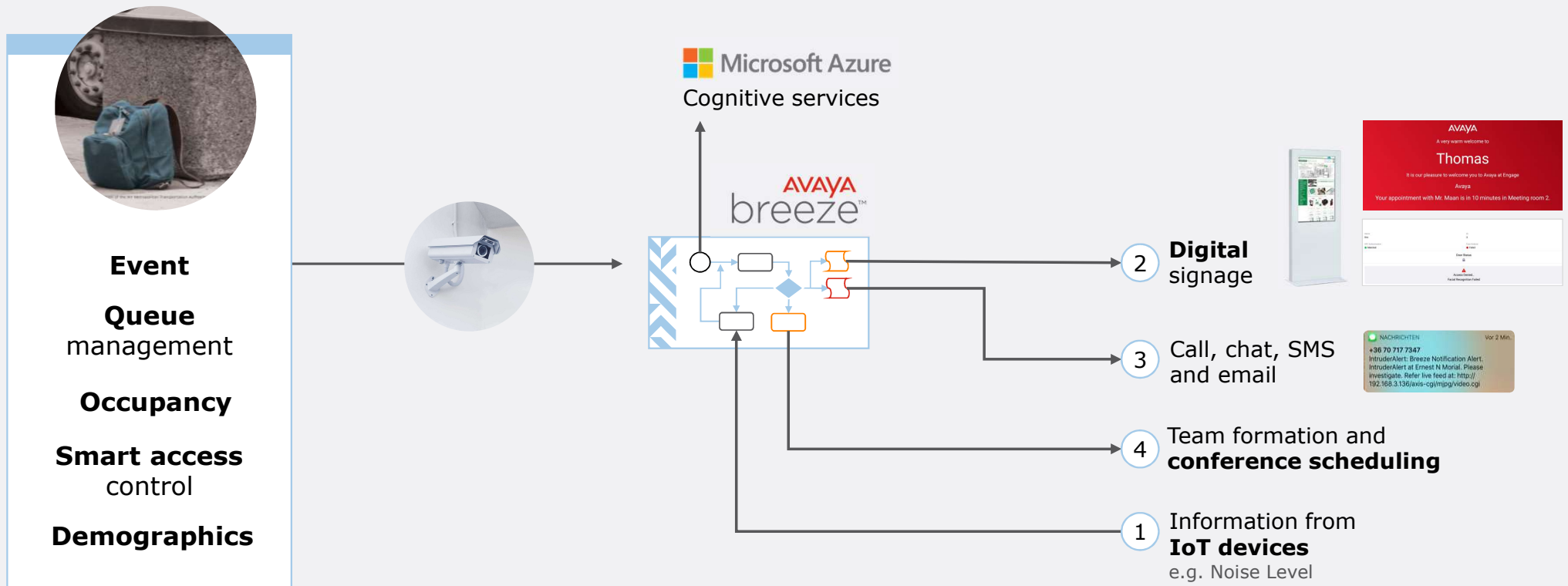

# Avaya Smart City Framework

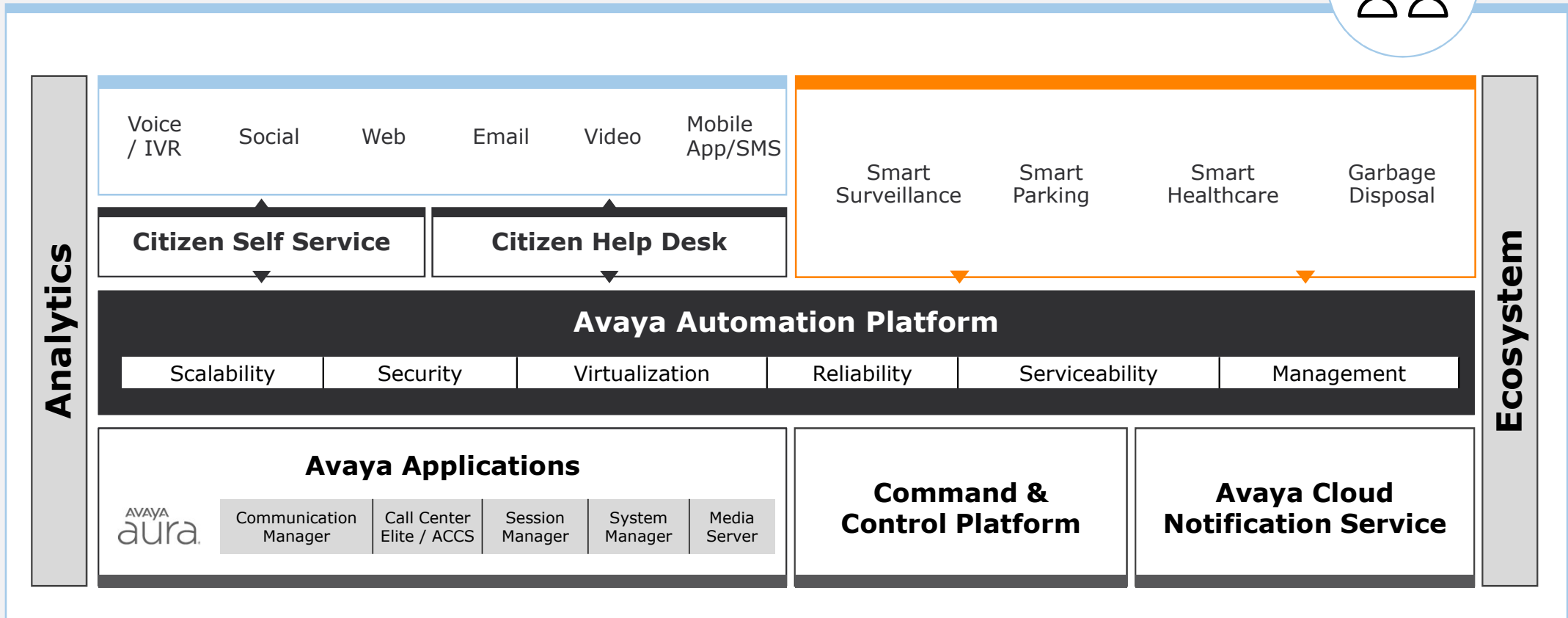
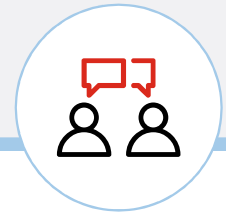

# Smart City = Smart Communications

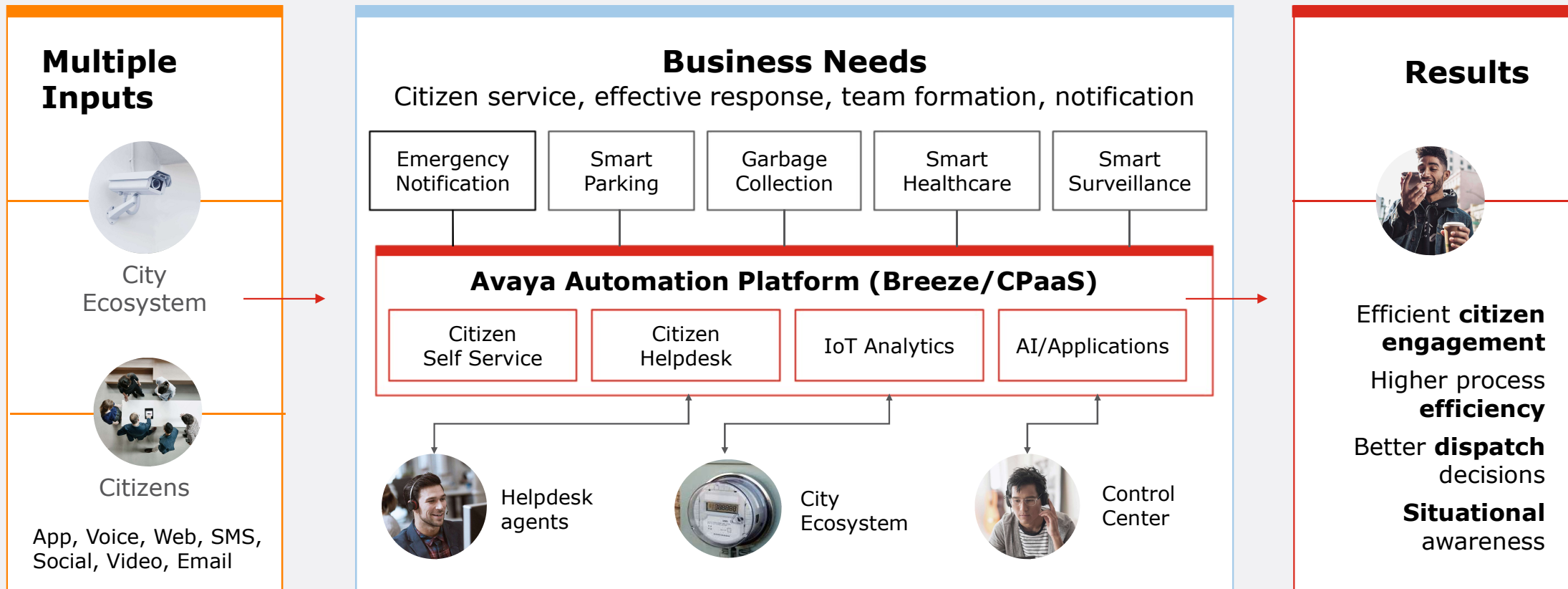



# The Kiosk for the Citizen



## Self Service

**Self help for citizens** at strategic city locations

**Extend service** at the branch and the home

Video **self-help, wait-treatment, two-way collaboration**

## Two-Way Conference Video

**Agent shares:**

Video

Documents

Web Pages

# Smart Notification



# Threat Detection & Omni-Channel Mass Notification

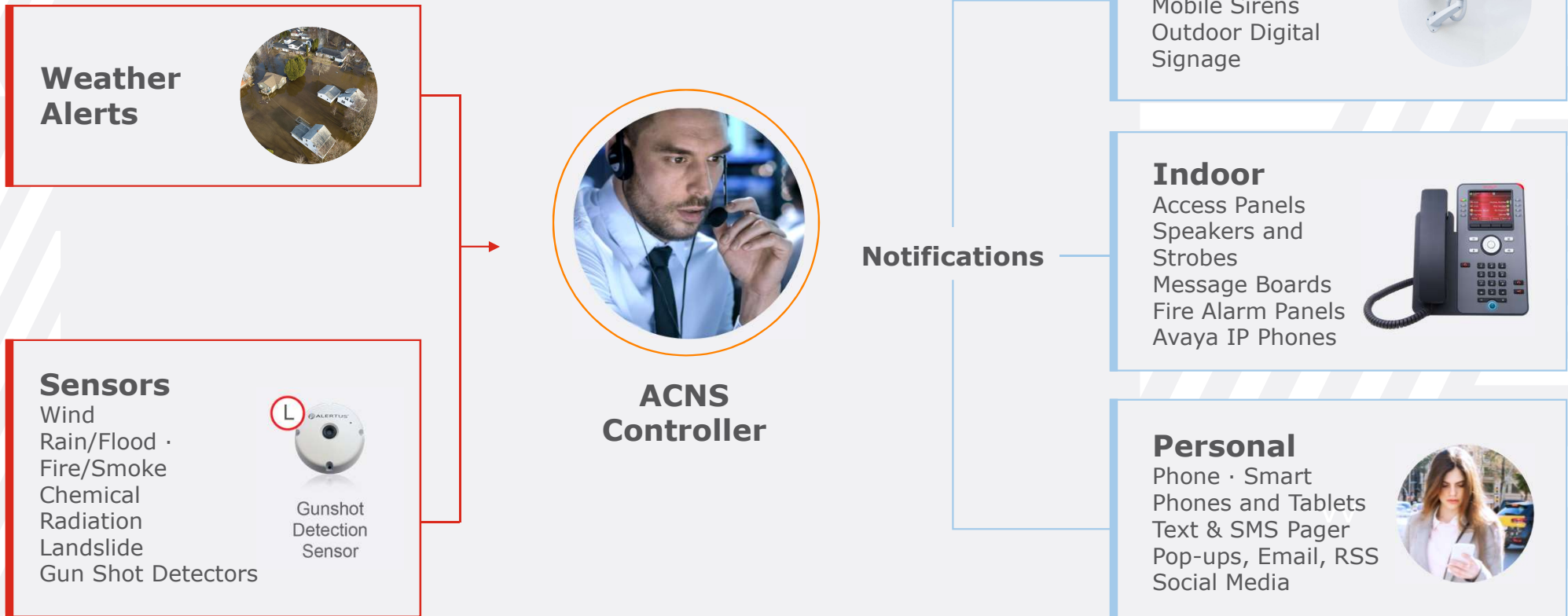

# Avaya ACNS - Omni Channel Notification -

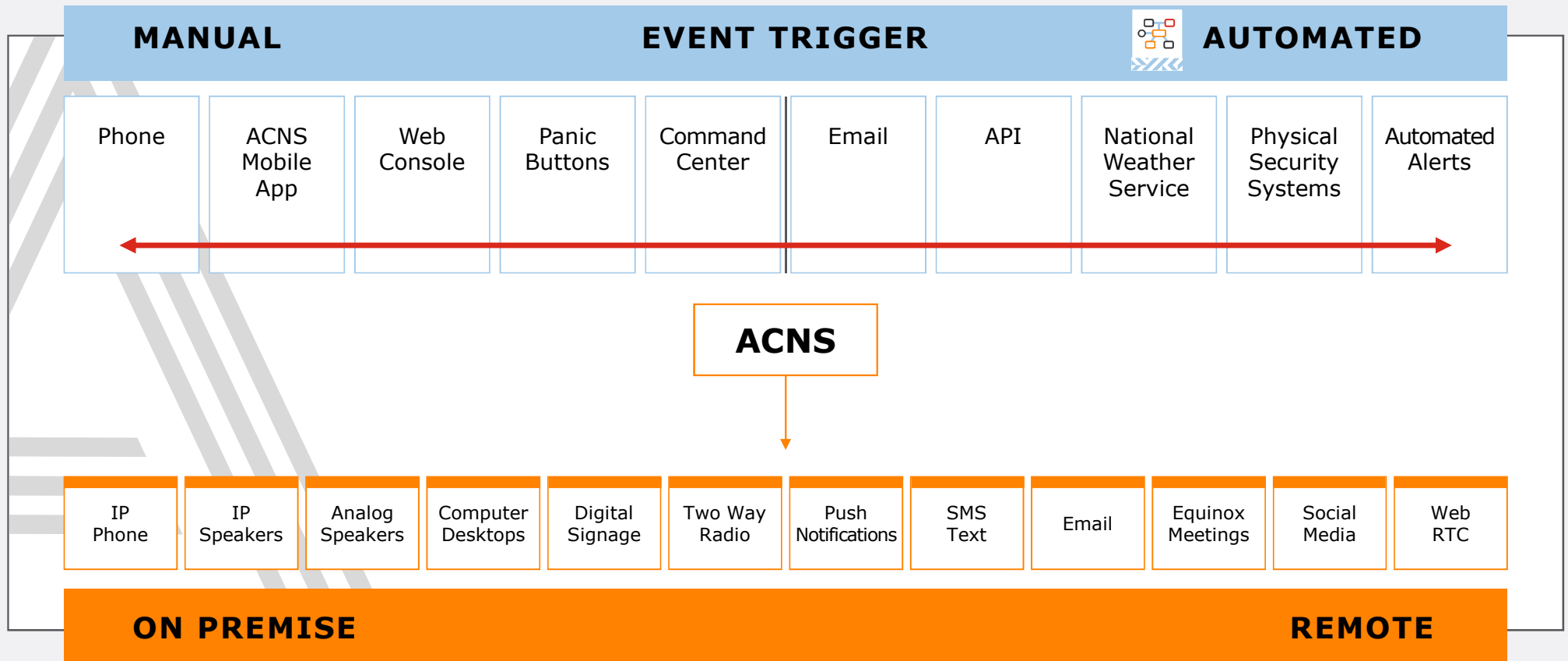

# Safety Status and Location

Advanced mission-critical interaction during an emergency

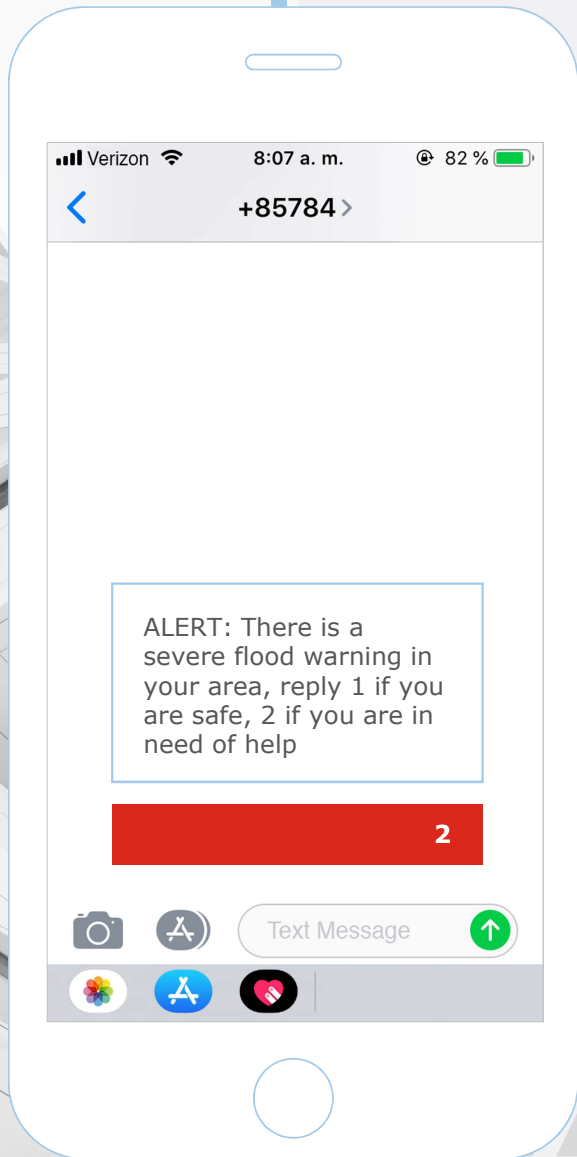

Triggered by premise equipment or manually

Location services

Output to emergency services

Real-time awareness

No app install necessary

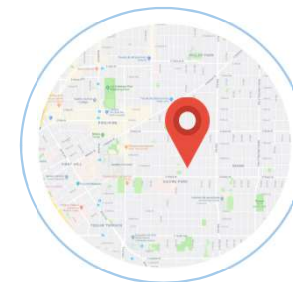

# Avaya IoT Reference Architecture

Open by Default

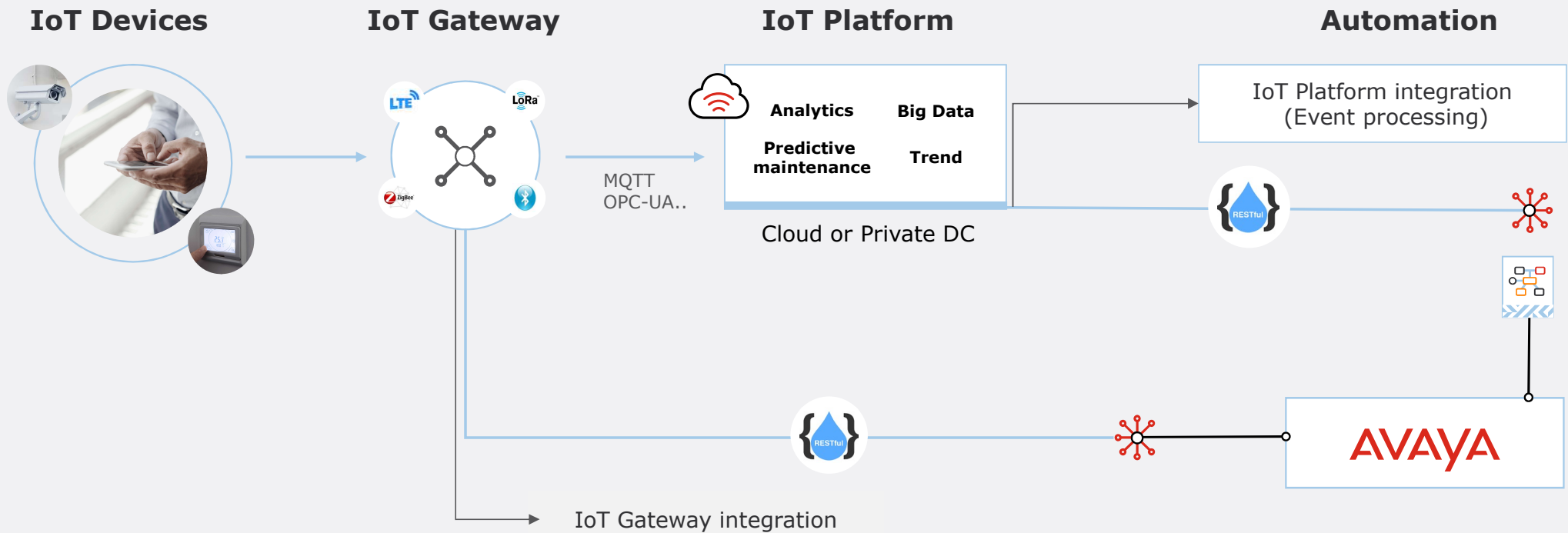

# YouTube Demo Videos

## Smart Parking



<https://www.youtube.com/watch?v=rd267Nwn-M0>

## Smart Waste Management



[https://www.youtube.com/watch?v=MGiLYo1j\\_X8](https://www.youtube.com/watch?v=MGiLYo1j_X8)

## Cops & Robbers

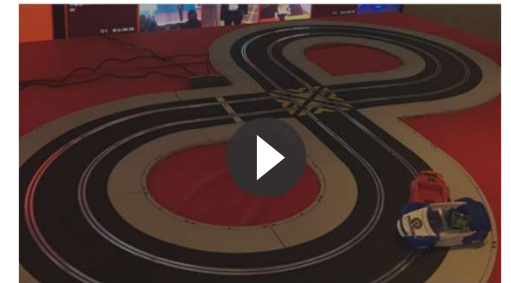

<https://www.youtube.com/watch?v=Pu1ror6r0BQ>

<https://youtu.be/24qBOciIOd4>

# YouTube Demo Videos

## Smart Ordering

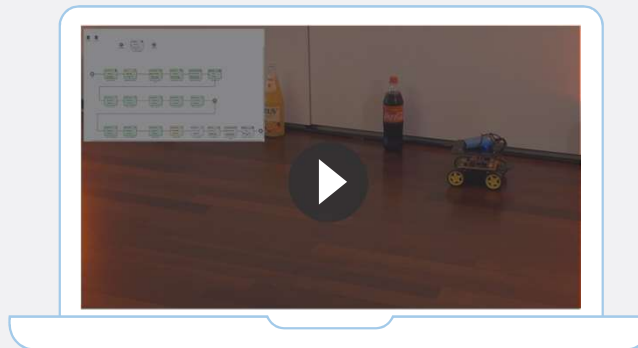

<https://www.youtube.com/watch?v=sKgdi5IXv7w>





## Recap

---

City administrators can drive more intelligent outcomes by **uniquely automating processes** and **seamlessly connecting citizens and employees** through a smart city ecosystem.

Avaya's Smart City Solutions intelligently connect and automate processes between people, machines, devices and LOB applications to ensure the right information is in the right place at the right time, maximizing business outcomes.



“Avaya provides the ability to seamlessly enable **IoT ecosystems** to communicate with any user or device **with the right information, in the right place at the right time.**”



**Thank You.**